

LUMIMAX[®] Illumination controller FLC1-xxx* - Technical data

Product image



Picture may differ from the original product

Description

- external mini illumination controller for flash operation
- Protection class IP67 enables use in difficult environmental conditions
- *available flash times:
 - Type FLC1-100 100 μ s / max. 100 Hz
 - Type FLC1-220 220 μ s / max. 35 Hz
 - Type FLC1-750 750 μ s / max. 10 Hz
- different trigger modes
- M8 mounting plugs & sockets for an easy, fast commissioning
- connection cable with an M8 5-pin socket in different lengths available as accessory (PUR-cable, limited drag chain compatibility)

Technical data

Operation mode	Flash	
Operation voltage	19...30 V DC	wide range voltage input (green status LED)
Trigger modes	TTL / SPS	TTL: rising slope at trigger input, min. 3 V DC, max. 30 V DC SPS: rising slope at trigger input, min. 15 V DC, max. 30 V DC (red status LED)
Flash times	100 μ s / 220 μ s / 750 μ s	max. flash frequency 100 Hz / 35 Hz / 10 Hz
Ambient temperature	5 - 45 °C / 37 - 113 °F	non-condensing
Material	Anodized aluminum	
Weight	0,12 kg / 0,26 lbs	
Protection class	IP 67	
Connection	M8 5-pin plug	
Tariff code	85399090	
Country of Origin	Federal Republic of Germany	

Pin arrangement M8 plug (5-pin)

1	brown	U_b	Operation voltage	
2	white	GND	GND Operation voltage	
3	blue	GND Trigger	GND trigger circuit	
4	black (long)	+Trigger SPS	SPS > 15 V, rising slope	
5	grey	+ Trigger TTL	TTL > 3 V, rising slope	
	black (short)	Shield	Shield connection	

Illumination controller FLC1-xxx* - Technical drawing

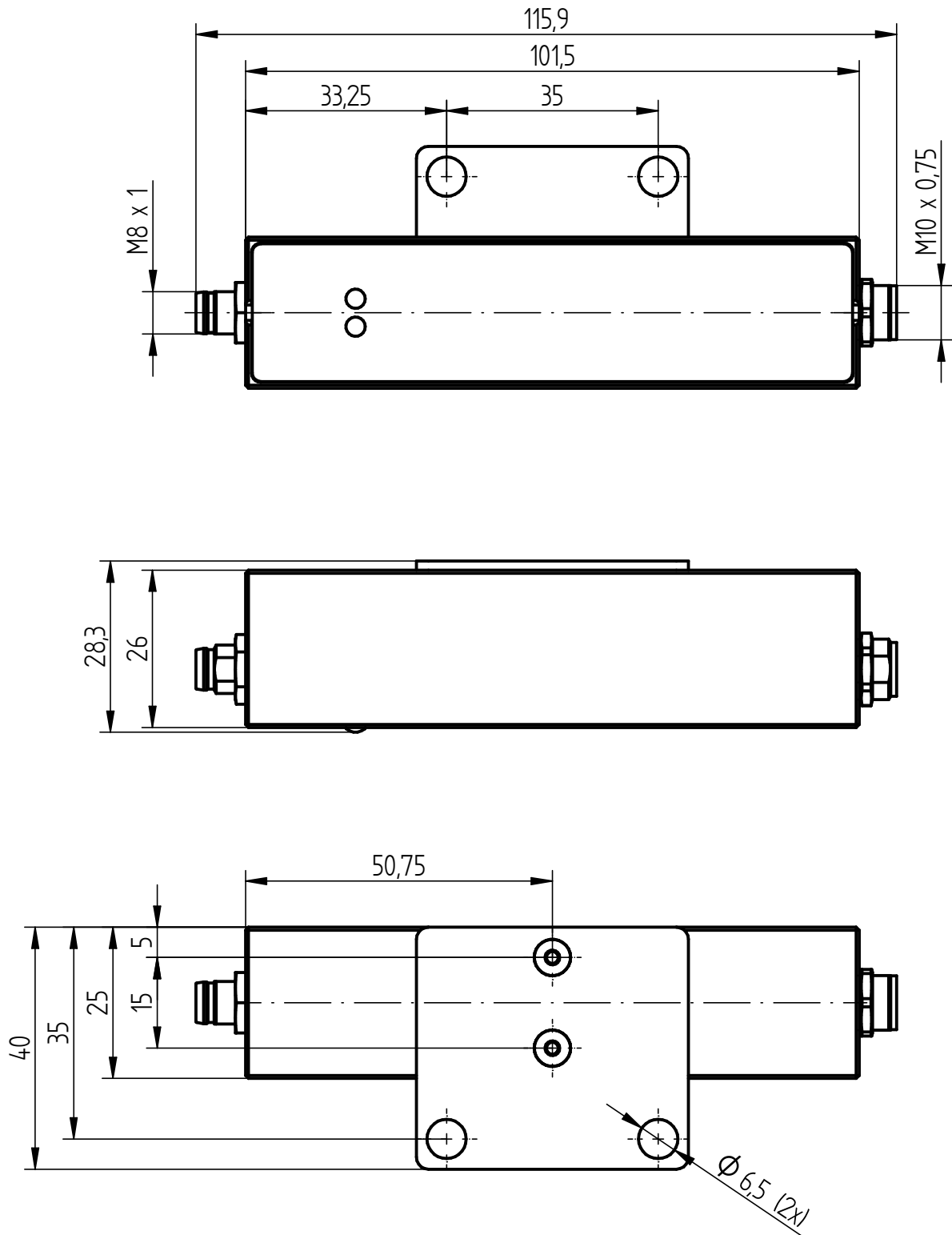

Maintenance & FAQ

Intended Use

LUMIMAX[®] LED lights are exclusively intended as components for Machine Vision systems, that are used for quality control as well as process control and optimisation in industrial installations.

- Use the lights in enclosed rooms only.

Intended Use

Initial operation

- Have the light only put into operation by trained specialists and in compliance with the specified protective measures. Adhere to the permissible environmental conditions.
- For optimal heat dissipation, mount the largest possible surface of the light on thermally conductive machine elements.
- Keep cooling fins free to ensure sufficient convection.

Status LEDs

Most lights have 2 status LEDs on the (rear) side. The light only illuminates when both status LEDs light or blink.

- The green status LED signals the connection to the correct operating voltage.
- The red status LED blinks when a switching or trigger signal is connected to the light.

Protection class

LUMIMAX[®] LED lights with protection class IP64 and higher are protected against dust, contact and splash water on all sides in accordance with the applicable standards. Permanent protection against liquids containing solvents, such as e. g. cleaning agents, machine emulsions or other lubricants cannot be guaranteed.

Ageing-related brightness decrease of the LEDs

The brightness of LEDs decreases over time due to natural ageing. LUMIMAX[®] LED lights are designed and manufactured in such a way that at full load operation under the permissible ambient conditions at least the following expected operating hours are achieved or exceeded without the light's intensity falling by more than 30% compared to the delivery condition:

- 80,000+ h for LUMIMAX[®] LED lights in the visible and infrared wavelength range
- 55,000+ h for LUMIMAX[®] High Power LED lights in the ultraviolet wavelength range
- 21,000+ h for LUMIMAX[®] High Power LED Spot lights in the ultraviolet wavelength range

The ageing is significantly influenced by the mounting conditions in the machine, the ambient temperature, and the operating mode of the lighting. Switching or flashing can significantly reduce the decrease in brightness of the LEDs and thus of the light. Further information concerning this topic you could find [> here](#).

Troubleshooting

The device does not light up.

The green status LED does not light up.

- Check if the light is connected as described on the data sheet and that the correct operating voltage is set. If you are using a power supply with current limiting, increase the allowable current.

The green status LED does light up.

- Check whether the light has been dimmed. Carefully turn the brightness potentiometer clockwise. For variants with an active VC brightness regulation, check if the VC voltage input is correctly connected and a control voltage of at least 2 V DC is applied.
- For lights with switching input and for flash lights check that the necessary switching or trigger signals are present. The status LED should blink red when a trigger is released.

Care and Maintenance

The LED lights from iIM AG usually do not need maintenance. Should it still be necessary to clean the external glass and plastic surfaces or device components, then observe the following:

- Do not use acetone, methylated spirits or other solvents.
- For cleaning the plastic surfaces use a soft, lint-free cloth moistened with soapy water or a normal glass cleaning cloth.

Disposal



LUMIMAX[®] LED lights and cables are registered at Stiftung Elektro-Altgeräte Register[®] under WEEE Reg. No. DE 48985193.

- Ensure the separate collection of electrical and electronic equipment. Beforehand, a non-destructive removal of the LEDs is not possible.
- On request, the iIM AG will handle the proper disposal of returned LED lights. Contact via [> info@iimAG.de](mailto:info@iimAG.de)

The aims of the Packaging Act (VerpackG) are the avoidance or reduction, reuse and recycling of packaging waste to protect the environment.

- Properly recycle packaging waste.