

## Modular Area Lights of the ML series

### Product Image

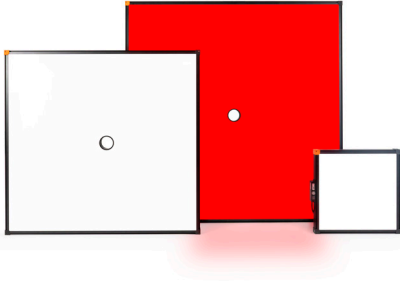

Pictures may differ from the original

### Technical Specifications

Illumination colours   Wavelengths	White (5700 K) Red   625 nm Infrared   850 nm
Optional camera hole (positioned centrally)	Ø 35 mm Ø 50 mm Ø 75 mm
Light direction	Homogeneous, highly diffuse area light, ideal for backlight applications (DL)
Operating modes	Continuous / switch oder flash operation
Controller	Integrated illumination or flash controller
Operating voltage	19 to 30 V DC wide-range voltage input
TTL trigger	High level = 3 to 30 V DC
PLC trigger	High level = 15 to 30 V DC
Continuous operation	Assign + ON / OFF permanently with high signal, e. g. by applying to operating voltage Connect GND ON / OFF
Switch operation	Switching time follows the switching signal Connect + ON / OFF and GND ON / OFF
Flash operation	Rising slope Adjustable flash times   Maximum flash frequency From 10 to 100 µs   100 Hz From 20 to 220 µs   35 Hz From 50 to 750 µs   10 Hz
Electrical connection	150 mm connecting cable with M16 12-pin plug
Brightness control via potentiometer	0 % (left stop) to 100 % (right stop) brightness
Brightness control via analogue VC input	VC = 2 to 10 V DC (0 % to 100 % brightness) Note: Turn potentiometer to left stop
Allowed ambient temperature	5 to 45 °C, non-condensing
Protection class	IP40
Material Casing   Screen	Aluminium, anodised   PMMA
Tariff code	85395100
Country of Origin	Federal Republic of Germany

### Pin Assignment

	U <sub>B</sub>	LUMIMAX <sup>®</sup>
brown	+ 24 V DC	
white	GND	
<b>Trigger</b>		
pink	PLC +24 V DC	
grey	TTL +5 V DC	
blue	GND	
<b>VC</b>		
yellow	2...10 V DC	

Pin	Colour	Assignment	Function	Image
A+K	White	GND	GND operating voltage	
B+L	Brown	U <sub>B</sub>	Operating voltage	
C	Green	NC	NC	
D	Yellow	VC	Brightness control 2...10 V DC	
E	Grey	+ trigger TTL	Switching / flash input (rising slope) TTL > 3 V DC	
F	Pink	+ trigger PLC	Switching / flash input (rising slope) PLC > 15 V DC	
G	Blue	GND trigger	GND trigger circuit	
H	Shield	Shield	Shield Connection	
J	NC	NC	NC	
M	NC	NC	NC	

**Available Sizes**

- only without camera hole
- with or without camera hole
- only with camera hole

With the lighting concept of the ML series, larger light fields than those shown here can also be achieved. Other shapes, illumination colours, lighting characteristics, etc. are also possible.

The LUMIMAX<sup>®</sup> team will be happy to support you in implementing your application.

		Y																				
Light Area in mm		50	100	150	200	250	300	350	400	450	500	550	600	650	700	750	800	850	900	950	1000	
Number of modules		1	2	3	4	5	6	7	8	9	10	11	12	13	14	15	16	17	18	19	20	
Controller side X	250	5	●	●	●	●	●															
	300	6	●	●	●	●	●	●														
	350	7	●	●	●	●	●	●	●													
	400	8	●	●	●	●	●	●	●	●												
	450	9	●	●	●	●	●	●	●	●	●											
	500	10	●	●	●	●	●	●	●	●	●	●										
	550	11	●	●	●	●	●	●	●	●	●	●	●									
	600	12	●	●	●	●	●	●	●	●	●	●	●	●								
	650	13	●	●	●	●	●	●	●	●	●	●	●	●	●							
	700	14	●	●	●	●	●	●	●	●	●	●	●	●	●	●						
	750	15	●	●	●	●	●	●	●	●	●	●	●	●	●	●	●					
	800	16	●	●	●	●	●	●	●	●	●	●	●	●	●	●	●	●				
	850	17	●	●	●	●	●	●	●	●	●	●	●	●	●	●	●	●	●			
	900	18	●	●	●	●	●	●	●	●	●	●	●	●	●	●	●	●	●	●		
	950	19	●	●	●	●	●	●	●	●	●	●	●	●	●	●	●	●	●	●	●	
	1000	20	●	●	●	●	●	●	●	●	●	●	●	●	●	●	●	●	●	●	●	●

**Maximum Irradiance in W/m<sup>2</sup> (working distance 0 mm)**

The Area Lights of the ML series reach the following maximum irradiances. Lights with a larger number of modules than the specified maximum number achieve lower irradiance in proportion to its size. The exact value can be determined by selecting the configuration.

Colour	Continuous / switch operation	Flash operation
● Red	193 W/m <sup>2</sup> for max. 76 modules	1600 W/m <sup>2</sup> for max. 105 modules
● Infrared	201 W/m <sup>2</sup> for max. 85 modules	1580 W/m <sup>2</sup> for max. 167 modules
○ White	190 W/m <sup>2</sup> for max. 119 modules	1530 W/m <sup>2</sup> for max. 199 modules

Select Your configuration here.

**Light Area**

Length X in mm

Width Y in mm

**Illumination colour**

**Operating mode**

Product Title (example)

**ML CB50** - 400 x 400 **FL - DL - R** -100

only for  
flash mode

optional camera hole	length X	width Y	DL	R	flash time
side	50			IR850	
Ø Z	100			W	-100
35 mm	250	150			-220
50 mm	300	200			-750
75 mm	350	250			
	...	...			
	1000	1000			

Technical Drawing

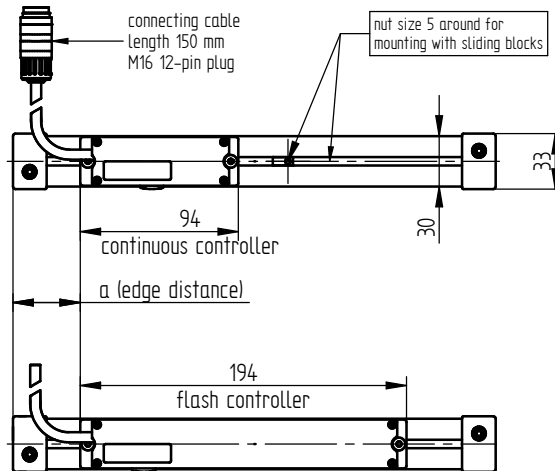
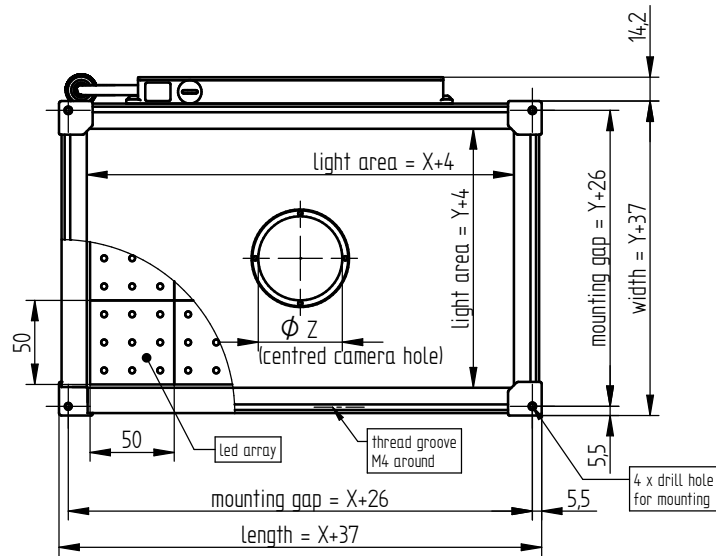

◀ Controller position a

- for lengths from 250 mm to 450 mm
  - controller positioned centrally

- for lengths from 500 mm
  - distance to casing edge  $a = 220$  mm

## Assembling

flat installation with mounting brackets

### LMW-ML (optional accessory)

**Art. No.: 105.100000.01**

Mounting set with 2 mounting brackets, 4 sliding blocks incl. screws and washers (M5x8)

- fastening using size 5 sliding blocks in the circumferential nut
- mounting on at least 2 opposite sides
- using 2 mounting brackets per side is recommended with an edge length > 500 mm

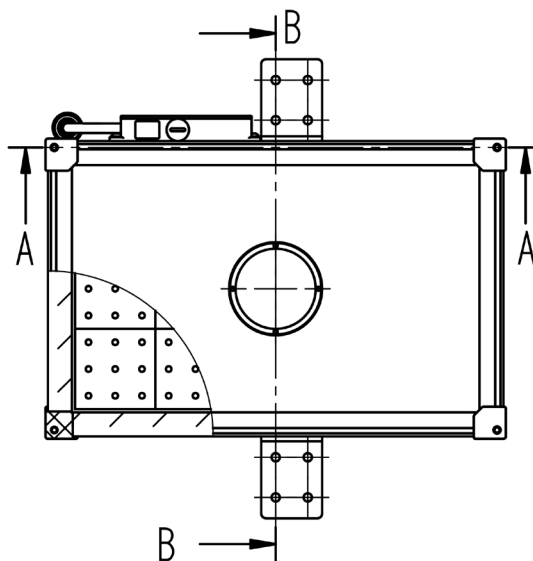

corner fixation of the lighting  
 (not suitable for hanging installation)

- screw connection using M4 thread pre-assembled nuts
- screw connection using a through hole and M3 thread

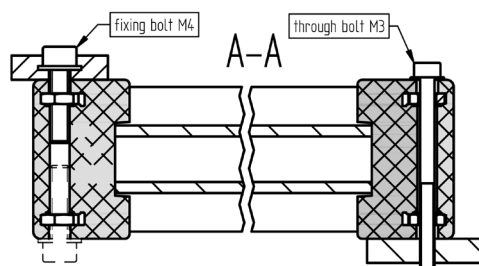

lateral installation using a size 5 sliding block in the circumferential nut

optional cover of the surrounding M4 thread groove using a cover profile to protect against dirt and dust

### ML Cover Profile M4 (optional accessory)

**Art. No.: 105.100000.10**

- Material TPE
- available preassembled by the meter

### ML Cover Profile Nut 5 (optional accessory)

**Art.-Nr.: 105.100000.11**

- Material PP
- available preassembled by the meter

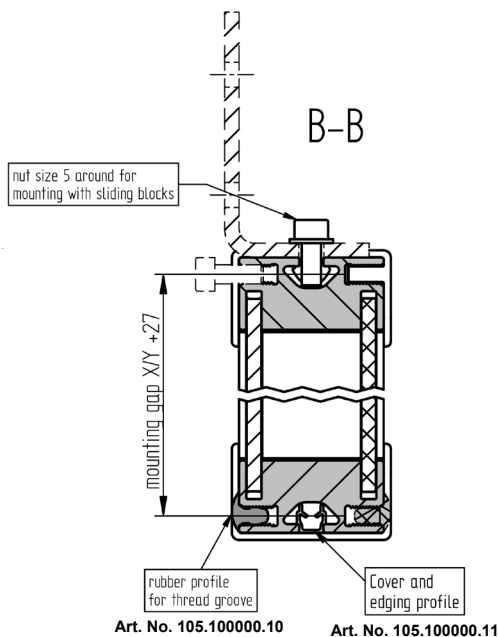

## Modular Area Lights of the ML series

### Warnings

#### Photobiological safety - visible light



**Caution!** The lighting emits optical radiation light in a wavelength region between 400 nm and 750 nm. This is visible to the human eye. It can glare and/or cause irritation and damage to the eyes and skin. Observe the following risk group classifications and protective measures. The use of additional optical accessories (e. g. lenses, interchangeable screens/frames) can lead to a change of the risk group. For further help ask the LUMIMAX<sup>®</sup> Service&Support Team.

#### Hazard related risk group labelling

Illumination Colour	RG 0 (exempt)	RG 1	RG 2	RG 3
Visible light	No requirements	No requirements	<b>CAUTION</b> Hazardous optical radiation may be emitted from this product	<b>WARNING</b> Hazardous optical radiation may be emitted from this product

#### Instructions for protective measures

Illumination Colour	RG 0 (exempt)	RG 1	RG 2	RG 3
Visible light	No requirements	No requirements	Do not look at operating light for a long time. May be harmful to the eye.	Do not look at operating light. Eye injury may result.

#### Photobiological safety - infrared



**Caution!** The lighting emits optical radiation in the infrared region (wavelength > 750 nm). This is invisible to the human eye. It can cause irritation and damage to the eyes and to the skin. Observe the following risk group classifications and protective measures. The use of additional optical accessories (e. g. lenses, interchangeable screens/frames) can lead to a change of the risk group. For further help ask the LUMIMAX<sup>®</sup> Service&Support Team.

#### Hazard related risk group labelling

Illumination colour	RG 0 (exempt)	RG 1	RG 2	RG 3
IR	No requirements	<b>NOTICE</b> IR radiation emitted from this product	<b>CAUTION</b> IR radiation emitted from this product	<b>WARNING</b> IR radiation emitted from this product

#### Instructions for protective measures

Illumination colour	RG 0 (exempt)	RG 1	RG 2	RG 3
IR	No requirements	Do not look at operating light for a long time. Use appropriate shielding.	Do not look at operating light for a long time. Avoid eye exposure. Use appropriate shielding.	Do not look at operating light. Avoid eye exposure. Use appropriate shielding.

#### Hot housing surfaces



**Caution!** High ambient temperatures and insufficient heat dissipation lead to hot housing surfaces. These can cause burns if touched. Do not touch the light during operation. Maintain a minimum distance of 20 mm between the light and thermally insulating surfaces or mount the light on a thermally conductive surface.

#### Cooling fins

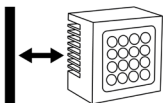

**Caution!** Keep the cooling fins of the light free at all times during operation. Covered cooling fins lead to insufficient heat convection and thus to a significantly increased housing temperature. This can cause burns if touched as well as a reduction of the lights' service life.

## Maintenance & FAQ

### Intended Use

LUMIMAX<sup>®</sup> LED lights are exclusively intended as components for Machine Vision systems, that are used for quality control as well as process control and optimisation in industrial installations.

- Use the lights in enclosed rooms only.

### Intended Use

#### Initial operation

- Have the light only put into operation by trained specialists and in compliance with the specified protective measures. Adhere to the permissible environmental conditions.
- For optimal heat dissipation, mount the largest possible surface of the light on thermally conductive machine elements.
- Keep cooling fins free to ensure sufficient convection.

#### Status LEDs

Most lights have 2 status LEDs on the (rear) side. The light only illuminates when both status LEDs light or blink.

- The green status LED signals the connection to the correct operating voltage.
- The red status LED blinks when a switching or trigger signal is connected to the light.

#### Protection class

LUMIMAX<sup>®</sup> LED lights with protection class IP64 and higher are protected against dust, contact and splash water on all sides in accordance with the applicable standards. Permanent protection against liquids containing solvents, such as e. g. cleaning agents, machine emulsions or other lubricants cannot be guaranteed.

#### Ageing-related brightness decrease of the LEDs

The brightness of LEDs decreases over time due to natural ageing. LUMIMAX<sup>®</sup> LED lights are designed and manufactured in such a way that at full load operation under the permissible ambient conditions at least the following expected operating hours are achieved or exceeded without the light's intensity falling by more than 30% compared to the delivery condition:

- 80,000+ h for LUMIMAX<sup>®</sup> LED lights in the visible and infrared wavelength range
- 55,000+ h for LUMIMAX<sup>®</sup> High Power LED lights in the ultraviolet wavelength range
- 21,000+ h for LUMIMAX<sup>®</sup> High Power LED Spot lights in the ultraviolet wavelength range

The ageing is significantly influenced by the mounting conditions in the machine, the ambient temperature, and the operating mode of the lighting. Switching or flashing can significantly reduce the decrease in brightness of the LEDs and thus of the light. Further information concerning this topic you could find [> here](#).

### Troubleshooting

#### The device does not light up.

The green status LED does not light up.

- Check if the light is connected as described on the data sheet and that the correct operating voltage is set. If you are using a power supply with current limiting, increase the allowable current.

The green status LED does light up.

- Check whether the light has been dimmed. Carefully turn the brightness potentiometer clockwise. For variants with an active VC brightness regulation, check if the VC voltage input is correctly connected and a control voltage of at least 2 V DC is applied.
- For lights with switching input and for flash lights check that the necessary switching or trigger signals are present. The status LED should blink red when a trigger is released.

### Care and Maintenance

The LED lights from iim AG usually do not need maintenance. Should it still be necessary to clean the external glass and plastic surfaces or device components, then observe the following:

- Do not use acetone, methylated spirits or other solvents.
- For cleaning the plastic surfaces use a soft, lint-free cloth moistened with soapy water or a normal glass cleaning cloth.

### Disposal



LUMIMAX<sup>®</sup> LED lights and cables are registered at Stiftung Elektro-Altgeräte Register<sup>®</sup> under WEEE Reg. No. DE 48985193.

- Ensure the separate collection of electrical and electronic equipment. Beforehand, a non-destructive removal of the LEDs is not possible.
- On request, the iim AG will handle the proper disposal of returned LED lights. Contact via [info@iimAG.de](mailto:info@iimAG.de)

The aims of the Packaging Act (VerpackG) are the avoidance or reduction, reuse and recycling of packaging waste to protect the environment.

- Properly recycle packaging waste.

### Compliance



EU and UK Documents of Conformity for all LUMIMAX<sup>®</sup> lights are available on request.

UK Representative: PKG Consultants LLP, 38 Northgate, Newark, Nottinghamshire NG24 1EZ, United Kingdom